

CY310P / CY310PV Specification Sheet

- * Made In Taiwan
- * Insulation Cl. : E / F
- * Inverter Ready, 3 Phase, Optional

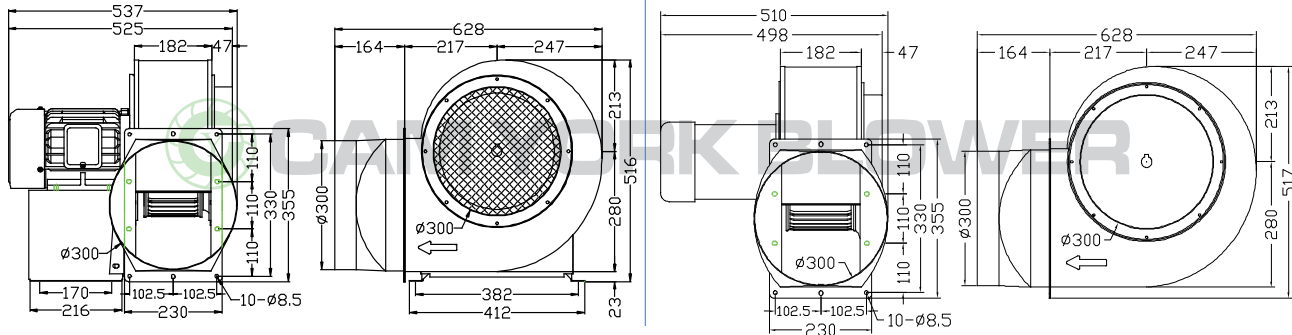

Model	Rated Voltage	Frequency	Phase	Pole	Current	Power	Speed	Max. Air Flow			Max. Pressure			Weight	
	V	Hz	Ø	P	A	Watt/HP	R.P.M.	CMM	CMH	CFM	mmAq	inchAq	Pa		KG
CY310P	220	50	1	4	8	2 HP	1450	56	3360	1977	68	2.68	667	42	
		60			11.5		1720	67	4020	2365	100	3.94	981		
	220/380	50	3		5.9 / 3.3		1450	60	3600	2118	65	2.56	637		
		60	7 / 4.1		1710		70	4200	2471	94	3.70	922			
CY310PV	220/380	50	3	6	7.3 / 4.3	3 HP	1450	68	4080	2400	73	2.87	716	49	
		60			8.5 / 4.8		1710	80	4800	2824	104	4.09	1020		
	110/220	50	1		7.5 / 3.8		970	43	2580	1518	33	1.30	324		39
		60			9.4 / 4.8		1150	51	3060	1800	47	1.85	461		

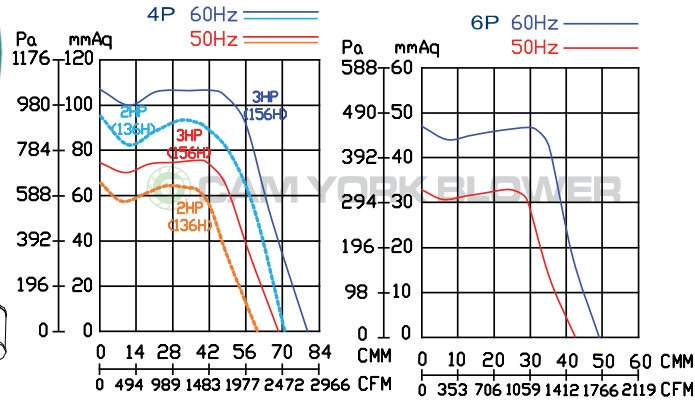
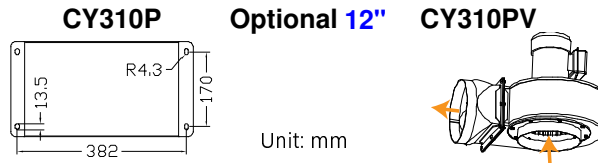

CAM YORK INDUSTRIAL CO.,LTD.
 No. 9, Ln. 308, Jinzhou Rd., Wufeng Dist., Taichung City
 41350 , Taiwan

TEL:04-23322627
 FAX:04-23322629
 E-mail: blower-cy@umail.hinet.net
 http://www.blower.com.tw/